

## **TP-2**

### **CATHODIC OSCILLOSCOPE**

**(1<sup>st</sup> Part + 2<sup>nd</sup> Part)**

#### **1- The purpose**

The goal of this experiment is to learn how to perform various signal measurements using the oscilloscope.

#### **2- Reminder**

The oscilloscope is a measuring instrument that allows you to visualize the variations of a voltage as a function of time or as a function of another voltage. It also enables the measurement of the frequency of alternating signals and the phase difference between two signals.

#### **3- Measurement processes using the oscilloscope**

##### **3-1- Voltage measurement**

To measure voltage using one of the two channels of the oscilloscope, it is advisable to select a range in such a way that the peak-to-peak amplitude of the signal occupies most of the screen without overshooting (to reduce potential sources of error).

##### **Example of measurement**

Consider a sinusoidal signal  $V_e(t)$  applied to channel 1 of the oscilloscope with the range selector set to 0.5 V/cm. Its peak-to-peak value is:

Its peak-to-peak value is:

$$V_{e_{cac}} = \text{Number of Cm (Nb)} \times \text{scale (K}_V) = \text{Nb} \times K_V$$

$$V_{e_{cac}} = 4 \text{ Cm} \times 0.5 \text{ V/Cm} = 2 \text{ V Peak-to-peak (càc)}$$

$$V_{e_{max}} = 2 \text{ V} / 2 = 1 \text{ V}$$

##### **3.2 Frequency measurement**

To measure the frequency of a signal, choose a time-based setting such that the period of the signal occupies the majority of the horizontal length of the screen.

##### **Example of measurement**

Consider a signal  $V_e$  applied to channel 1 of the oscilloscope, where the time base range selector is set to 0.5 ms/cm.

$$T = \text{Nb de cm (Nb)} \times \text{scale (K}_s) = \text{Nb} \times K_s$$

$$T = 10 \text{ cm} \times 0.5 \text{ ms/cm} = 5 \text{ ms} = 5 \cdot 10^{-3} \text{ s}$$

$$\text{Hence, } f = 1/T = 0,2 \times 10^{-3} = 200 \text{ Hz.}$$

##### **3.3 Phase measurement**

To measure the phase difference between two signals, it is necessary to observe them simultaneously. For this purpose, both voltages should be referenced to the same point, which is the ground point.

##### **First method: direct method**

Consider two signals with a phase difference; the phase shift (in degrees) is:

$$\varphi = \frac{t}{T} \times 360^\circ$$

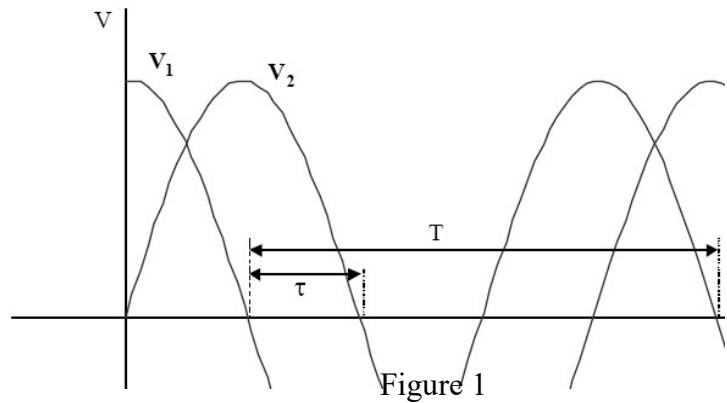

Figure 1

**Measurement Example:**

Consider two signals  $V_e$  and  $V_s$ , where  $V_s$  is phase-delayed compared to  $V_e$ . Reading from the screen:  $T = 10$  cm and  $t = 2.5$  cm.

Therefore  $\varphi = \frac{t}{T} \times 360^\circ = \frac{2.5}{10} \times 360^\circ = 90^\circ$

**Second method: Lissajous method (two signals of the same frequency)**

This method involves obtaining curves in a plane by displacing a plane whose coordinates are functions of the same parameter.

To use this method, set the oscilloscope to a horizontal sweep.

Note: Before taking measurements, position the spot at the center of the axes (center of the screen).

$$X = V_e(t) = A \sin(\omega t)$$

$$Y = V_s(t) = B \sin(\omega t + \varphi)$$

With:  $a = 2Y_{X=0}$  et  $b = 2Y_{\max}$

It is shown that:  $\sin(\varphi) = a/b$  donc:  $\varphi = \arcsin(a/b)$

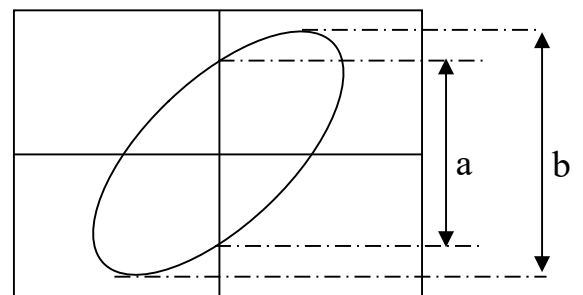

Figure 2

**Measurement Example:**

Consider the ellipse below where:

$a = 4$  div et  $b = 6$  div

So:  $\sin \varphi = a/b = 4/6 = 0.66$

Hence:  $\varphi = \arcsin(0.66) = 0.72$  rad

$0.72$  rad  $= 41^\circ$

This method does not provide information about the direction of the phase shift.

**4- Necessary equipment**

01	Oscilloscope	01	Variable Resistor
01	Voltage Generator	02	Fixed Resistors
01	Low-Frequency Signal Generator (GBF)	01	Capacitor
		01	Voltmeter

**MANIPULATION**

**1- Amplitude measurement**

Using the voltage generator, apply an alternating voltage to the input of channel 1 on the oscilloscope:

- Complete table 1.
- Record the signal point by point on graph paper for one of the values.
- Interpret the results.

V (Generator)	2	8	15
Scale(Caliber) V/Cm			
Nb. of Cm peak to peak			
V peak to peak (V)			
V max = $V_{c\grave{a}c} / 2$ (V)			
V on the voltmeter (V)			
Veff = $V_{max} / \sqrt{2}$ (V)			

Table 1

### 2- Visualization of two voltages

The oscilloscope also allows the visualization of two voltages. To achieve this, activate the button that selects both channels.

-Make the connections as shown in Figures 1 and 2.

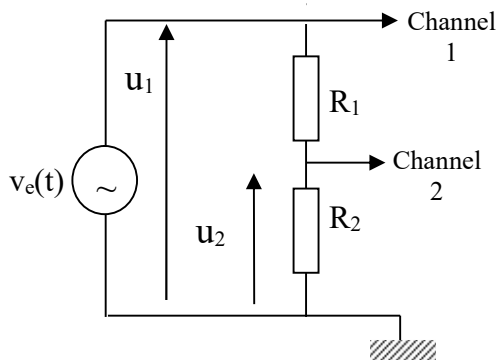

Figure 3a

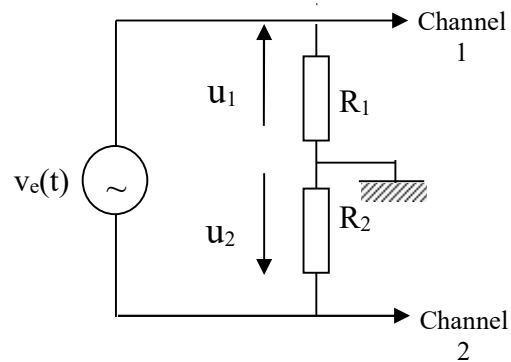

Figure 3b

- Plot for both configurations  $u_1$  and  $u_2$  when:  
 $v_e(t)$  is alternating voltage.  
 $v_e(t)$  is direct voltage.
- What can we conclude?

### 3- Frequency Measurement

Using the GBF, apply a sinusoidal, square then triangular signal to the input of channel 1 of the oscilloscope: complete table 2.

Signal	Sinusoidal	Square	Triangular
F (Hz) displayed on GBF	200	500	1000
Time base setting ms/cm			
NB. of Cm per period			
T(s)			
$F=1/T$ (Hz)			

Table 2

- Interpret the results.

## 4-PHASE SHIFT MEASUREMENT

### 4.1. Direct method.

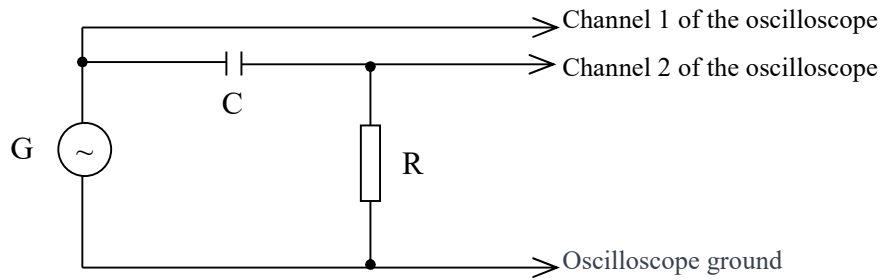

Figure 4

- Assemble the setup shown in Figure 4,  
G is an alternating voltage generator set at **6V**,  
C is a capacitor with a value of **1 $\mu$ F**,  
R is a variable resistor.
- Adjust the resistance according to Table 3 and determine the phase shift for each value of R.

R(K $\Omega$ )	2	4	8
T(cm)			
t(cm)			
$\varphi = (t / T) \cdot 360^\circ$			

Table 3

- Interpret the results.

### 4.2. Lissajous method

For the same setup as that in Figure 4, determine the phase shift according to Table 4.

R(K $\Omega$ )	2	4	8
a(cm)			
b(cm)			
$\sin \varphi = a/b$			
$\varphi = \arcsin(a/b) (^\circ)$			
$\varphi$ (rad)			

Table 4

- Interpret the results.
- What happens to the phase shift if R increases indefinitely?

# Annex

## Cathode Oscilloscope

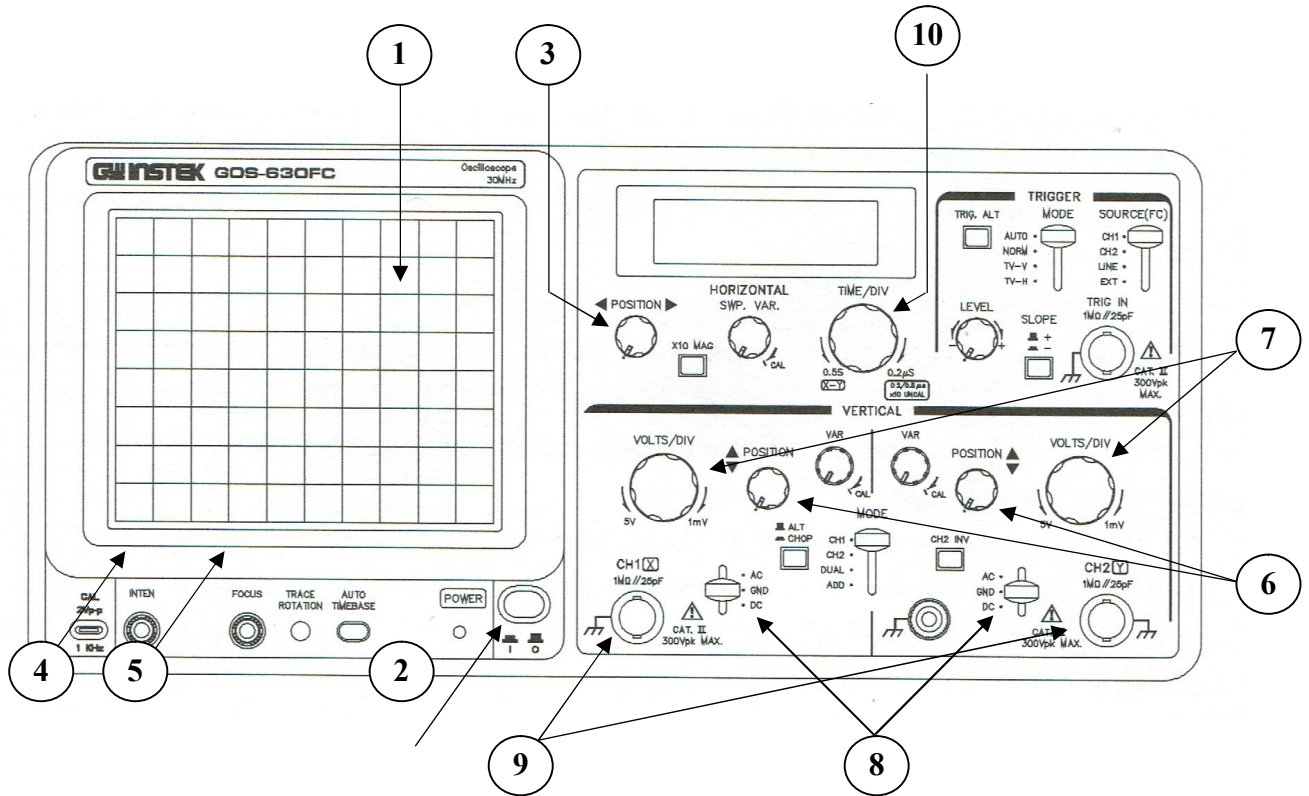

- 1- Screen.
- 2- Power On/Off Button.
- 3- Horizontal (X) Adjustment.
- 4- Light intensity.
- 5- FOCUS (Sharpness).
- 6- Adjustment of the ordinates (Y).
- 7- Amplitude Scale Selector Switch (V/Cm).

- 8- Switch (AC/DC/GND).  
GND : Ground.  
DC : Direct current.  
AC : Alternating current.
- 9- Inputs (Channels I, II).
- 10- Time Base.